

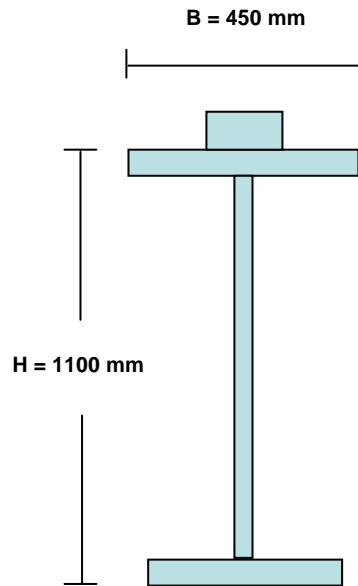

Zweiträger - Aussen Brückenkrane inkl. Kranbahn

- Hersteller: T + H / MAN
- Baujahr: 1993
- Tragkraft: 2 x 20,0 to → 40,0 to
- Spannweite: 34.500 mm
- nutzbarer Hakenweg: 11,0 m
- inkl. Funkfernsteuerung

- Kranbahn:**
- Fahrweg: ca. 16 x 12,0 m → 192,0 m
 - Gesamtlänge: ca. 384,0 m



Kranbahn

- Gesamtlänge: ca. 64 x 12,0 m → 768,0 m
- Träger mit aufgeschweißter Fahrschiene 60 x 60 mm

Portalkran 20,0 to / 5,0 to



- Hersteller: KSR Rheinberg
- Baujahr: ca. 1988 / 1995
- Tragkraft: Haupthub: 20,0 to ; Hilfshub: 5,0 to
- Spurweite: ca. 27.000 mm
- Ausladung: ca. 7.000 mm
- Hakenhöhe: ca. 12.500 mm
- inkl. Funkfernsteuerung

Schienenanlage:

- Fahrweg: ca. 105 m
- Gesamtlänge: ca. 210 lfm.



Elementdecken- Fertigungsbahnen

- Hersteller: AVERMANN
- Baujahr: ca. 1997
- Länge: ca. 2 x 50,0 m → 100,0 m
- Fertigungsbreite: ca. 2,40 m
- Gesamtbreite: ca. 2,50 m
- inkl. Rüttelschlitten



Schalungsanlage für gewendelte Treppen

- Hersteller: HOWAL
- Baujahr: ca. 1997
- Typ: ALPHAPLUS 175 / 270
- Geschosshöhe: bis ca. 4,0 m
- 23 Stufen



Mattenschneidemaschinen



Traversen bis 25,0 to



Baustahlbiegemaschinen



Formatkreissägen



Vertikale- Plattensägen



Mattenbiegemaschinen bis 6,0 m

Zusatz- Equipment